

# QC20-W wireless ballbar system description and specifications



**Hardware**

**Software**

# QC20-W ballbar and ballbar kit

## QC20-W ballbar



The QC20-W ballbar contains a precision linear transducer of Renishaw's own design (patent applied for). It is used to measure variations in radius as the ballbar is rotated around a fixed point. This data is used to calculate overall measures of positioning accuracy (circularity, circular deviation) in accordance with international standards such as ISO 230-4 and ASME B5.54/57. It also provides a detailed diagnosis of contributing individual error sources when analysed using Renishaw's unique diagnostic report format. Data is displayed graphically as well as in numeric format to support diagnosis.

Signal processing is carried out within the ballbar and data transmitted to a suitable PC using a Bluetooth® Class 2 module. There is an LED status indicator built into the housing covering communications, battery and fault status indication.

A standard (non rechargeable) CR2 lithium ion battery is supplied with each unit, although the system electronics also allow for the use of rechargeable CR2 type batteries.

## Zerodur® calibrator

A Zerodur® calibrator is supplied with all QC20-W kits and is used to calibrate the length of a ballbar. This type of calibrator is manufactured from a material which has a temperature expansion coefficient of almost zero.



When used with the Zerodur® calibrator, the QC20-W ballbar measures the absolute radius of the tested tool path. The ballbar can therefore be used to provide absolute (rather than relative) errors for axis scaling and radial deviation values as required for ISO 230-4 and ASME B5.54/57 analyses.

In addition the software will automatically calculate the positional tolerance of the tested machine. (The positional tolerance value is an estimate of the planar, bi-directional positioning accuracy of the machine, within the area enclosed by the ballbar test, and under unloaded conditions)

The Zerodur® calibrator can calibrate 100, 150 and 300 mm lengths. The small circle kit contains a 50 mm Zerodur® calibrator.

## QC20-W ballbar kit

### Kit contents

- QC20-W wireless ballbar (and one CR2 battery)
- Centre pivot
- Tool cup
- 50, 150 and 300 mm extension bars
- Zerodur® calibrator
- System software (including manuals)
- Offset setting ball
- Machine validation cards
- Calibration certificates
- System carry case (the case includes cut-outs for the optional small circle and VTL adaptors)



## Testing capability

The standard QC20-W ballbar kit includes a 100 mm long ballbar assembly and 50, 150 and 300 mm long extension bars. By assembling the ballbar with different combinations of extension bars it is possible to carry out ballbar tests with 100, 150, 250, 300, 400, 450, 550 or 600 mm radii. With additional extensions it is possible to perform tests up to 1350 mm.

The optional small circle kit allows tests with a 50 mm radius and testing can also be carried out on two-axis machines and lathes using optional accessories (page 6).

## Partial arc testing

Redesigned ball mounts (including new centre pivot and tool cup extension) allow the QC20-W to carry out a 220° arc test in planes through the centre pivot axis. This means that you can carry out ballbar tests in three orthogonal planes without the need to reposition the centre pivot, so speeding up testing.



The results can also be used in the new “volumetric analysis” report function (see software section) with the assurance that all data has been gathered around the same reference point.

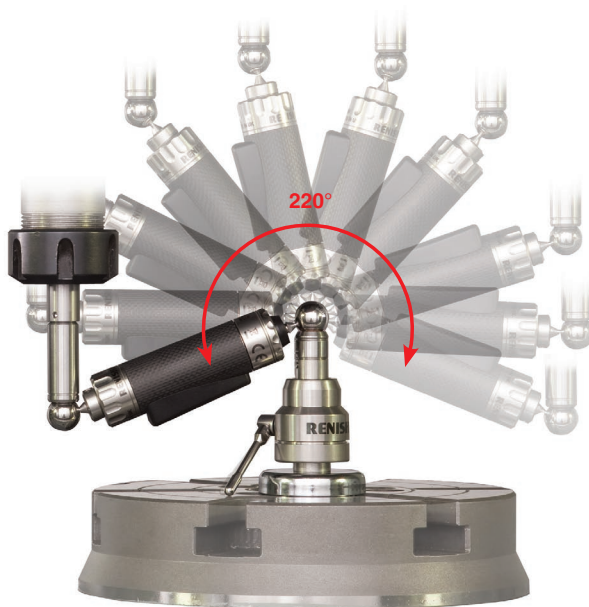

## Certificates and recalibration

All QC20-W ballbars are delivered with a detailed calibration certificate; your guarantee of accuracy. This also gives full traceability details in accordance with ISO 17025 requirements. Machine shops can be an aggressive environment and accidents that affect the ballbar’s performance can happen. Periodic recalibration is therefore recommended to give you confidence that the ballbar is still measuring within specification. In typical use we would suggest yearly recalibration (see website for further details). Renishaw’s QC20-W calibration service includes inspection and testing of your ballbar, replacement of tool cups and balls, comparison against a laser reference standard, computation of a new scale factor, and issue of a certificate of accuracy and traceability.

## System specification

<b>Sensor resolution</b>	0.1 µm (4 µin)
<b>Ballbar sensor accuracy</b>	±0.5 µm (at 20 °C) ±20 µin (at 68 °F)
<b>Maximum sample rate</b>	1000 values per second
<b>Data transmission</b>	Bluetooth, Class 2 (10 m typical)
<b>Extension bars</b>	50 mm, 150 mm, 300 mm
<b>Operating range</b>	0 °C - 40 °C (32 °F - 104 °F)
<b>Calibrator accuracies (at 20 °C)</b>	±1 µm (50 mm) ±1 µm (100 mm) ±1 µm (150 mm) ±1.5 µm (300 mm)
<b>System case dimensions</b>	(L x W x H) 395 mm x 300 mm x 105 mm
<b>System case weight</b>	3.75 kg (approx) incl. kit contents

# Measurement and diagnosis software

## Ballbar 20 software

Just like the QC20-W ballbar, Ballbar 20 software is powerful and easy to use. The intuitive interface and step-by-step instructions mean you can be using the system in minutes.

Key features are:

- Easy to use interface (Windows XP, Windows Vista®, Windows 7 compatible)
- Live data capture
- Analysis and display of test data in accordance with the latest ISO 230-4, JIS B 6190-4, B5.57 and B5.54 standards as well as extensive Renishaw analysis
- Positional tolerance value calculation
- Comprehensive, hyperlinked manual with hotlinks and search
- Multilingual support\*
- Powerful file and template administration utilities

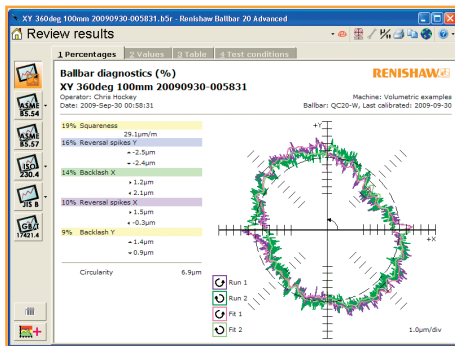

### Integrated manual

Integrated manual, with hotlinks and search.

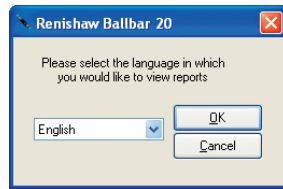

### Multilingual support

Ballbar 20 allows multi-language report generation as well as a choice of operating language.\*

In addition to a choice of standard test analysis functions, Ballbar 20 software includes:

## Part program generator

This facility allows the automatic generation of a part program for the specific ballbar test. To create a part program, all the user has to do is define a ballbar test or select an existing test template, select a pre-defined CNC controller definition and then click the "generate" button.

The part program generated can be reviewed on-screen prior to printing or exporting to a removable storage device.

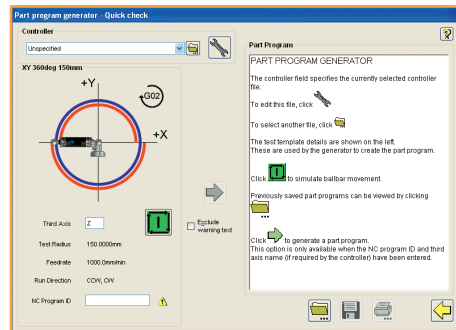

## Machine history

The machine history function allows you to build and review a test history for any specific machine. Just choose a test template and then select some or all of the tests in the machine folder.

The machine history function allows the variations in the performance of your machine over time to be displayed graphically, using any of the standard report values.

You can clearly see how your machine's performance has varied and can even "interrogate" individual plot points back to the original test report and polar graph.

In short, review a complete "medical record" for your machine!

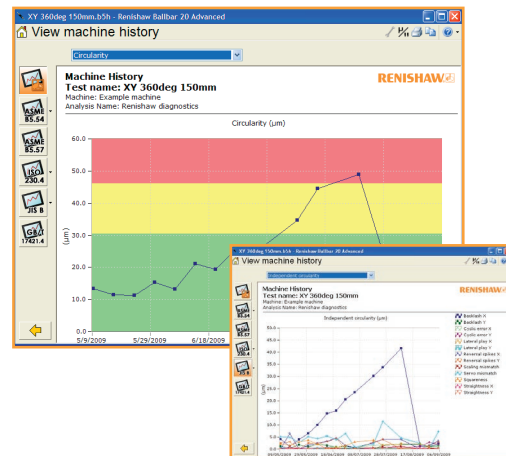

The software also allows you to:

- Set individual warning and failure performance bands for each machine characteristic
- Get instant notification, during the ballbar test, if a machine's performance exceeds these tolerances

\* Available in English, German, French, Italian, Spanish, Chinese, Japanese, Czech, Korean, Russian and Polish.

There's even a combined history plot which shows the independent circularity values for all parameters over time. This is a very useful "first stop" in reviewing the performance history of a machine and the relative importance of the errors that are present.

Machine history allows you to:

- See how machine performance is degrading with use
- Predict maintenance requirements in advance to reduce unscheduled downtime
- Compare performance before and after a crash to pinpoint corrective maintenance requirements
- Review the effects of maintenance and service adjustments as they are carried out
- Assess machine history to spot recurring problems, and the effectiveness of previous fixes

## Volumetric analysis

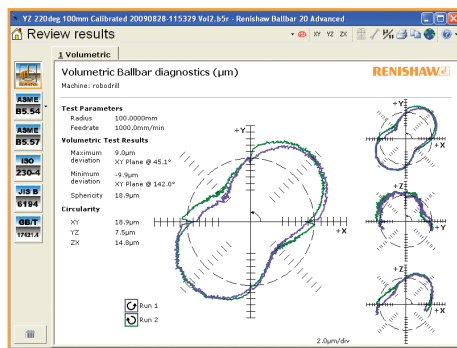

This is a new report option that allows the user to select three test files and then display a numeric "sphericity" result and the overall max and min circularity values. Graphical results are given for each of the three planes together with their individual circularity results. This analysis option also shows individual test circularity results. The volumetric analysis is only available when viewing results in the 'Renishaw analysis' and is not supported in ISO, ASME and other standards' analyses.

To ensure the validity of the analysis the software carries out checks on data files, e.g. consistent machine name, feedrate, radius and that test planes are orthogonal, and will only display an analysis if these criteria are met.

Volumetric analysis will only work with data captured using BB20 software, although this can be used with QC10 (3 off 360° tests), or QC20-W (360° plus 2 off 220° tests).

## Ballbar plot simulator

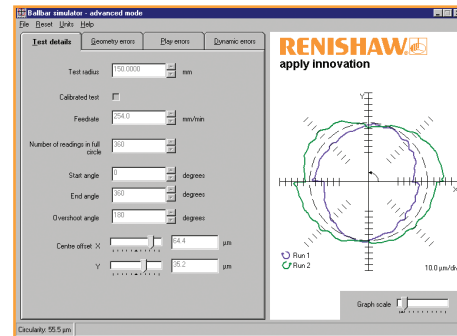

This is a powerful tool to aid decisions on corrective action or maintenance prediction. The simulator allows users to see their test results on screen and then to change various machine geometry, play and dynamic parameters to see "what if" results on the ballbar plot, circularity and positional tolerance values. The original test results are maintained separately and cannot be corrupted, no matter what scenarios are played out in the simulator.

## Ease of use

Despite such powerful features you only have to use those that you need, with three different user modes:

- Quick check - Use for one-off testing of machines with differing set-ups.
- Operator - Use for regular comparative testing of a machine's condition. Pre-defined test templates speed up the machine check and ensure consistency of set-up.
- Advanced - Full access to set up, edit and organise machine data.

### Ballbar 20 compatibility

Minimum computer requirements:

- Microsoft Windows® XP (SP2 or SP3) or Windows Vista®, Windows 7 compatible
- Minimum screen resolution 800 x 600 pixels
- CD-ROM drive (for software installation)
- Bluetooth enabled PC (Microsoft enumerator) or compatible Bluetooth-USB adaptor (ask Renishaw for current recommendations)

# System accessories

## Small circle accessory kit

The small circle accessory kit is used with the QC20-W ballbar to allow tests with a radius of 50 mm. This can be useful when testing machine axes with short axis travel, or to emphasise the effects of servo and dynamic errors on the machine (small circles require higher machine accelerations and decelerations).

The kit includes a 50 mm Zerodur® calibrator (and calibration certificate) and the small circle adaptor, which is supplied with an additional centre ball already fitted. The adaptor is a simple screw fitting to the main ballbar body. The kit is not recommended for use with the lathe accessory. The adaptor is available separately for customers upgrading from QC10 to QC20-W who already have a small circle accessory kit.



Contents of QC20-W small circle accessory kit

## VTL adaptor

For 2-axis CNC applications the VTL adaptor is available (this replaces the "tool cup" in the standard set-up and restricts movement of the centre cup to a single axis only.) This enables typical 2-axis machines such as vertical turning lathes and laser cutting machines etc, to benefit from QC20-W ballbar diagnosis.

With the zero position coordinates set, the VTL accessory allows for one magnetic cup to be withdrawn (to allow it to be driven to the test start position using the free axes' motion) and then be pulled forward (to the third axis zero position) without introducing any offset error in the other two axes.

The schematic below shows a typical application on a VTL where the tool head always runs along the Y axis on the centre-line of the rotary axis.

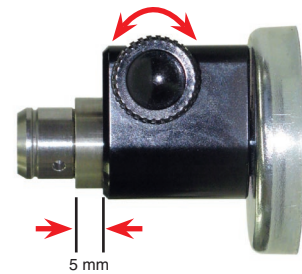

VTL adaptor restricts movement of the magnetic cup to 5 mm in one axis only.

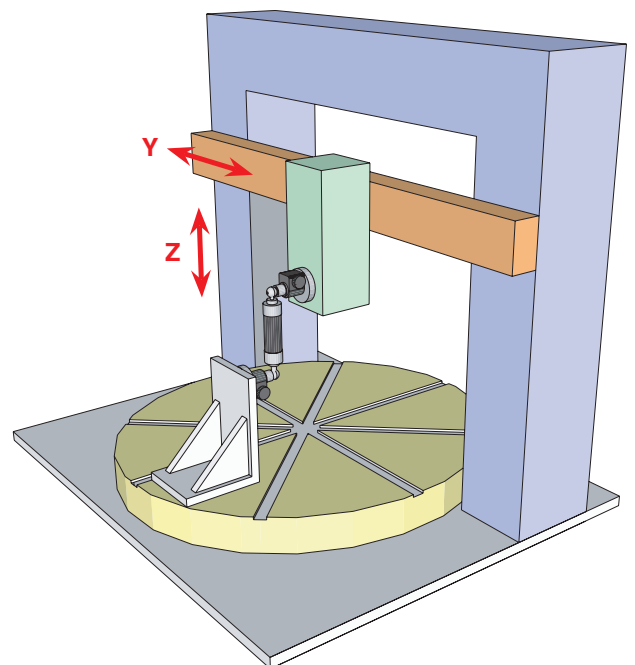
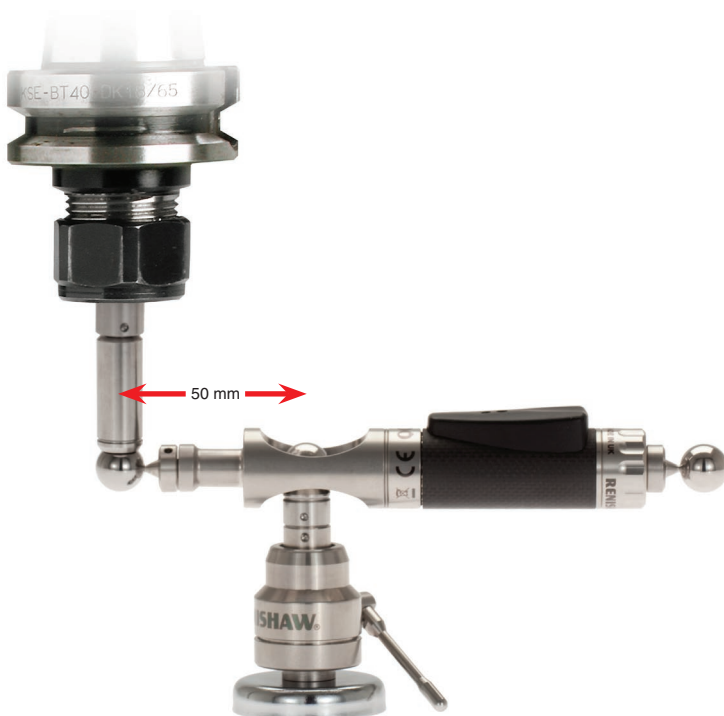

Typical two-axis vertical turning lathe showing VTL adaptor on tool holder.

## Lathe accessory kit

The lathe adaptor kit allows you to perform 360°, 100 mm radius ballbar tests on a lathe. The kit consists of an arm assembly for attachment to the lathe turret and a spindle bar for attachment in the lathe spindle. Both arm and spindle include magnetic cups in which to locate the ballbar; the one in the arm is equivalent to the tool cup in the normal kit set-up and the one in the spindle bar is equivalent to the pivot assembly/centre cup.

Note that to use this kit your lathe must have the following capabilities:

Axis clearance:	X-axis: 220 mm from centre-line Z-axis: 330 mm from chuck
Spindle diameter:	Ø25 mm (others will require additional magnetic base)
Tool holder:	accepts 20 mm or 25 mm tool shanks

On lathes with restricted axis travel it may be possible to perform a 50 mm radius test using the small circle accessory kit. However this set-up is not recommended because the test circle is performed a long way from the normal cutting zone, and because there is a danger the ballbar may dislocate from the magnetic cups during the test.



Lathe adaptor kit

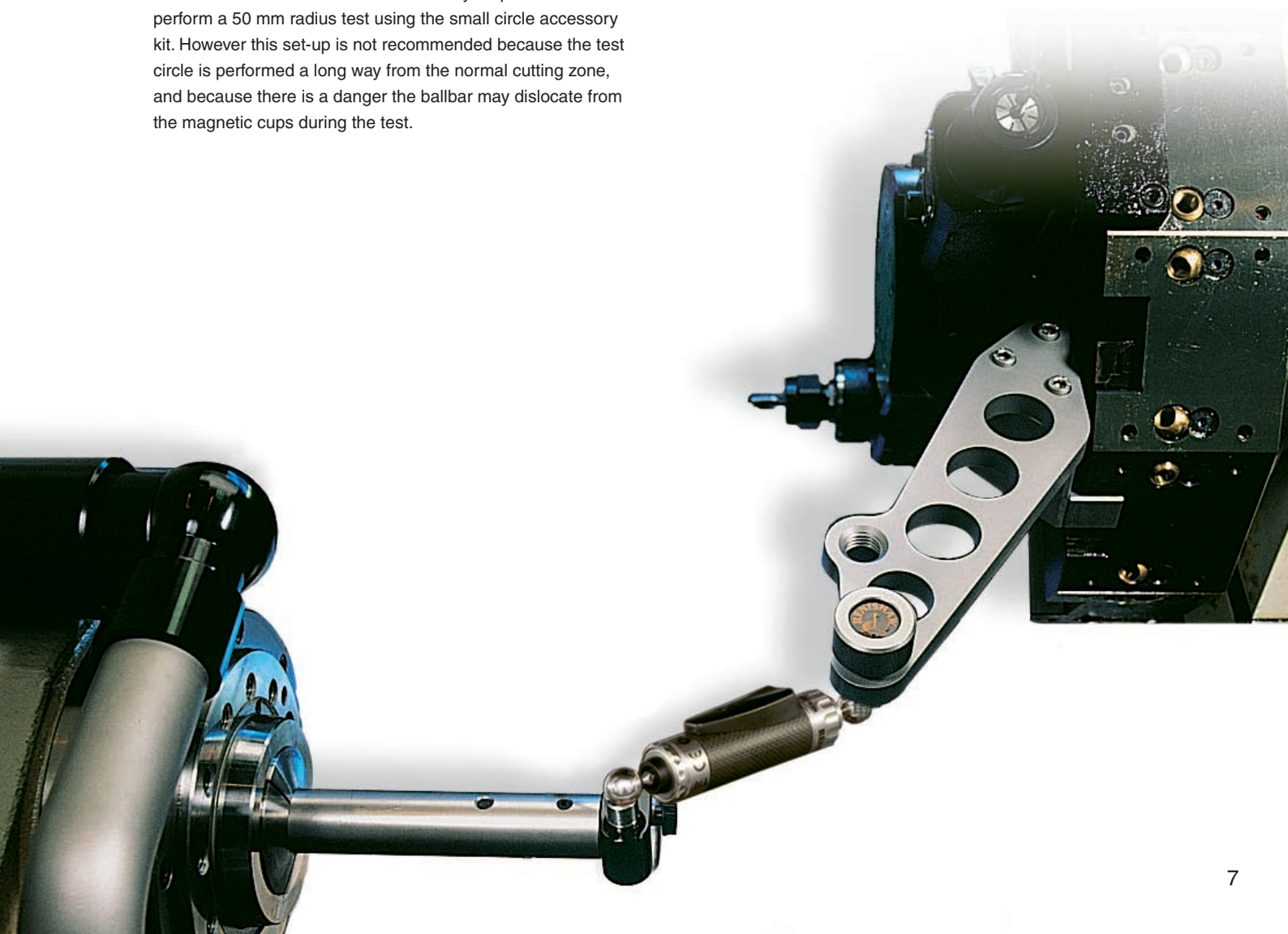

**Renishaw plc**  
New Mills, Wotton-under-Edge,  
Gloucestershire GL12 8JR  
United Kingdom

**T** +44 (0) 1453 524524  
**F** +44 (0) 1453 524901  
**E** uk@renishaw.com  
[www.renishaw.com](http://www.renishaw.com)

**RENISHAW**   
**apply innovation™**

## Renishaw applies innovation to provide solutions to your problems

Renishaw is an established world leader in metrology, providing high performance, cost-effective solutions for measurement and increased productivity. A worldwide network of subsidiary companies and distributors provides exceptional service and support for its customers.

Renishaw designs, develops and manufactures products which conform to ISO 9001 standards.

Renishaw provides innovative solutions using the following products:

- Probe systems for inspection on CMMs (co-ordinate measuring machines).
- Systems for job set-up, tool setting and inspection on machine tools.
- Scanning, digitising and dental systems.
- Laser and automated ballbar systems for performance measurement and calibration of machines.
- Encoder systems for high accuracy position feedback.
- Spectroscopy systems for non-destructive material analysis in laboratory and process environments.
- Styli for inspection and tool setting probes.
- Customised solutions for your applications.

## Renishaw worldwide

### Australia

**T** +61 3 9521 0922  
**E** australia@renishaw.com

### Austria

**T** +43 2236 379790  
**E** austria@renishaw.com

### Brazil

**T** +55 11 4195 2866  
**E** brazil@renishaw.com

### Canada

**T** +1 905 828 0104  
**E** canada@renishaw.com

### The People's Republic of China

**T** +86 21 6353 4897  
**E** china@renishaw.com

### Czech Republic

**T** +420 548 216 553  
**E** czech@renishaw.com

### France

**T** +33 1 64 61 84 84  
**E** france@renishaw.com

### Germany

**T** +49 7127 9810  
**E** germany@renishaw.com

### Hong Kong

**T** +852 2753 0638  
**E** hongkong@renishaw.com

### Hungary

**T** +36 23 502 183  
**E** hungary@renishaw.com

### India

**T** +91 80 6623 6000  
**E** india@renishaw.com

### Israel

**T** +972 4 953 6595  
**E** israel@renishaw.com

### Italy

**T** +39 011 966 10 52  
**E** italy@renishaw.com

### Japan

**T** +81 3 5366 5317  
**E** japan@renishaw.com

### Malaysia

**T** +60 3 5361 4420  
**E** malaysia@renishaw.com

### The Netherlands

**T** +31 76 543 11 00  
**E** benelux@renishaw.com

### Poland

**T** +48 22 577 11 80  
**E** poland@renishaw.com

### Russia

**T** +7 495 231 16 77  
**E** russia@renishaw.com

### Singapore

**T** +65 6897 5466  
**E** singapore@renishaw.com

### Slovenia

**T** +386 1 527 2100  
**E** mail@rls.si

### South Korea

**T** +82 2 2108 2830  
**E** southkorea@renishaw.com

### Spain

**T** +34 93 663 34 20  
**E** spain@renishaw.com

### Sweden

**T** +46 8 584 90 880  
**E** sweden@renishaw.com

### Switzerland

**T** +41 55 415 50 60  
**E** switzerland@renishaw.com

### Taiwan

**T** +886 4 2473 3177  
**E** taiwan@renishaw.com

### Thailand

**T** +66 2 746 9811  
**E** thailand@renishaw.com

### Turkey

**T** +90 216 380 92 40  
**E** turkiye@renishaw.com

### UK (Head Office)

**T** +44 1453 524524  
**E** uk@renishaw.com

### USA

**T** +1 847 286 9953  
**E** usa@renishaw.com

### For all other countries

**T** +44 1453 524524  
**E** international@renishaw.com