

QL-20™ Contour Projector®

The **QL-20** optical comparator is a precision instrument designed for the shop floor. QL-20 has extensive standard features and a range of options that allow you to configure a system to meet your specific measurement needs.

The eye level 20 inch diameter screen and conveniently located DRO make measurements fast and easy.

- Includes high brightness TruLight® LED profile illumination with variable intensity control
- High load capacity, nickel-plated worktable easily accommodates large, heavy machined parts and fixtures
- Optional VidiProbe video measurement and eCAD® virtual chart gage systems offer full automation

High Capacity Optical Comparator

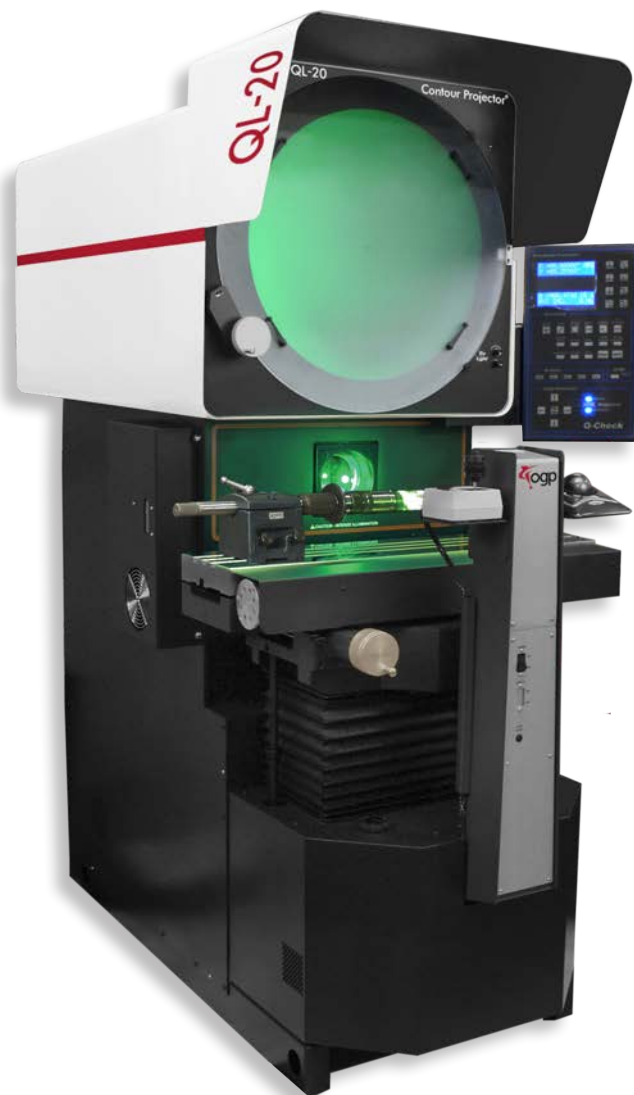

QL-20™ Contour Projector®

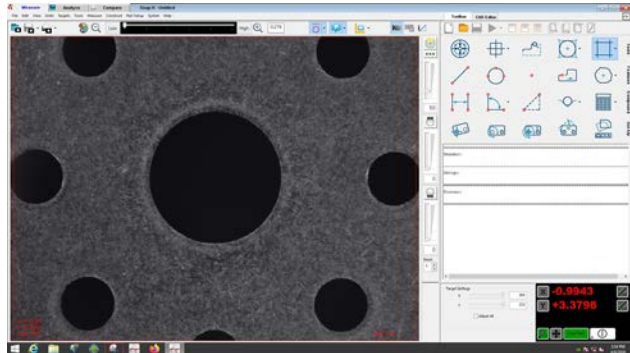

Transform the traditional optical comparator into a fully automatic inspection system with optional VidiProbe and SNAP-X™ software. The video camera is internally mounted to enable simultaneous measurements using both the analog comparator screen and the digital video with SNAP-X.

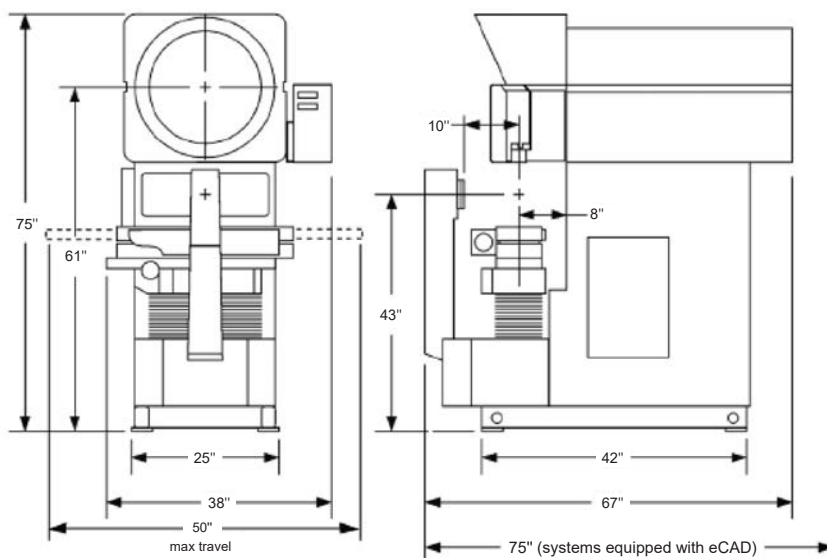

System Weight: 1,660 lb
Shipping Weight: 2,350 lb

	Standard	Optional
XY Travel Range	15" x 9"	15" x 10", 18" x 9", 18" x 10"
Helix Angle Range		±7.5° with pivoting worktable assembly and zero stop
Z Focus Travel	3" with precision fine adjustment	
Throat Clearance	19"	
XY Scale Resolution	0.00004"	0.00002"
XY Drive System	Motorized, DC servo, with variable speed joystick and X & Y axis manual fine adjustment	
Worktable	Heavy duty cast iron nickel plated worktable, 32" x 8"	
Recommended Maximum Load Capacity	250 lb	
Optical System	Telecentric with upright, un-reversed image	
Optical Options		Adjustable direct projection iris; Swing-away lamphouse; Overscreen Fresnel lens; Surface concentrator (requires optional surface light); VidiProbe video automation package; eCAD™ for electronic CAD overlay & virtual charts
Edge Detection		Projectron® internal automatic edge detection
Screen	20" diameter ground glass screen, with integral hood, 90° centerlines and clips for mounting standard overlay charts	
Protractor	Screen rotation protractor with ± 360° motion, digital display, 0.01° or 1' display	
Working Distance	8.4"	
Lens	10X	20X, 31.25X, 50X, 62.5X, 100X
Lens Mount	Fixed, one position mount	Internal, motorized 5 position lens turret with automatic magnification identification
Illumination	Green LED profile light with continuously variable intensity control	White brightfield LED through-the-lens coaxial surface light with continuously variable intensity
Electronics	QVI Q-Check®	Q-Touch
Software		SNAP-X Measure (included with VidiProbe); SNAP-X Compare (requires VidiProbe); SNAP-X Analyze (requires VidiProbe); eChek™ for automated CNC measurement; E-SPC; SmartReport
Accessories		Rotary indexer; Overhead light shield; Fixture and calibration reticles; Overlay charts
Power Requirements	100-120 VAC or 200-240 VAC, 50/60 Hz, 1ϕ, 1200 W	
Operating Environment, Safe Operation	15 - 30 °C	



Optical Gaging Products, a division of Quality Vision International
850 Hudson Avenue • Rochester, NY 14621 • USA
Phone: (585) 544-0400 • (800) 647-4243 • Fax: (585) 544-8092
info@ogpnet.com
www.ogpnet.com